

FL 100

Strain gauge training system



Description

- basic introduction to measurement with strain gauges
- test bars for tension, bending and torsion with strain gauge measuring points as full bridge
- universal 1-channel measuring amplifier

Strain gauges are used extensively in sensor systems to detect forces, moments and deformations.

The FL 100 experimental unit provides a wide-ranging introduction to the fundamentals of measurement by strain gauges. Three test specimens for tension, bending and torsion are each fitted with four strain gauge measuring points. The strain gauges are wired in the full bridge. The specimens are loaded incrementally allowing for the strain reading to be sequentially monitored.

The specimens can be inserted quickly and precisely into the frame. The strain gauge measuring range is protected by a Plexiglas cover, which also makes it clearly visible for inspection purposes. The measuring amplifier supplies the bridge supply voltage, and displays the load-dependent "bridge detuning" digitally in voltage values. The digital display also features a zero balancing function to allow for any preloading.

The various elements of the experiment are clearly laid-out and housed securely in a storage system.

Three additional tension bars are available as accessories, in brass (FL 100.01), copper (FL 100.02) and aluminium (FL 100.03), enabling the modulus of elasticity to be ascertained in experiments.

Learning objectives/experiments

- fundamentals of measuring with strain gauges
- strain gauge types and application techniques
- calculation of the mechanical deformations under tension, bending and torsion
- correlation between mechanical strain and electrical resistance in a strain gauge
- with FL 100.01, FL 100.02, FL 100.03: determination of the modulus of elasticity for various materials from the measuring data of a tensile test

FL 100

Strain gauge training system

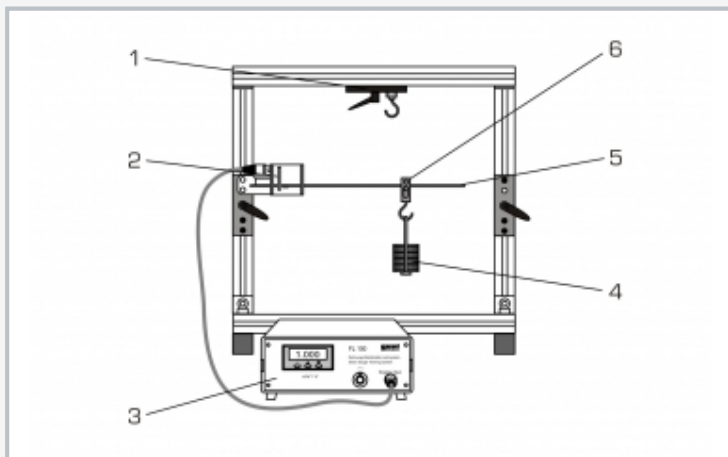

1 fixture, 2 strain gauge measuring point, 3 measuring amplifier, 4 weight, 5 bending bar, 6 adjustable rider

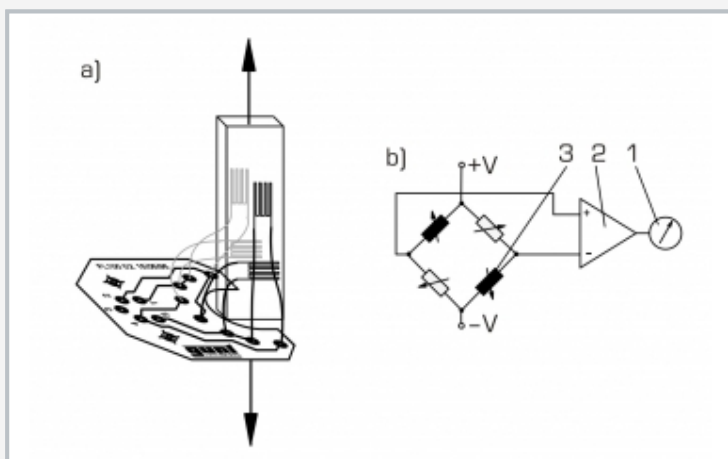

a) strain gauge arrangement on the tension bar (full bridge),
b) full bridge circuit: 1 display, 2 amplifier, 3 active strain gauge

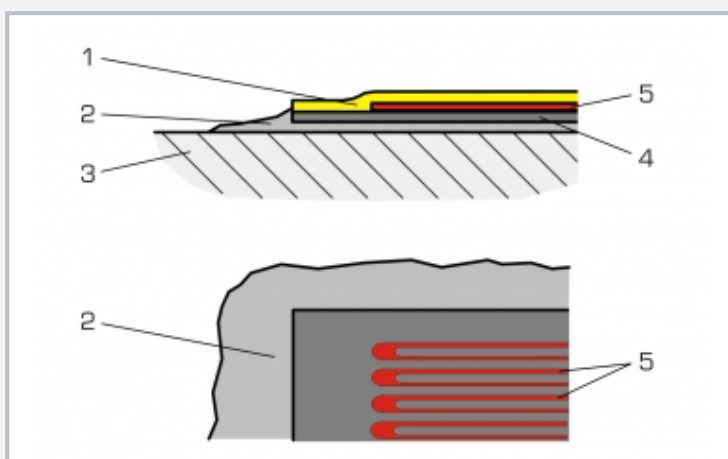

Layout of a strain gauge measuring point: 1 cover sheet, 2 adhesive, 3 component, 4 substrat, 5 gauge measuring grid

Specification

- [1] experimental unit investigating the fundamentals of strain gauge measurement
- [2] tension, bending and torsion tests each with strain gauge measuring points in full bridge circuit
- [3] strain gauge application areas protected by Plexiglas cover
- [4] steel test bodies
- [5] measuring amplifier with 4-digit digital display
- [6] frame to house the measuring objects
- [7] determination of modulus of elasticity on various materials using measuring objects FL 100.01, FL 100.02, FL 100.03
- [8] storage system to house the components

Technical data

Tension bar

- measuring length: 50mm
- cross-section: 2x10mm²
- modulus of elasticity: 191000N/mm²
- Poisson's ratio: 0,305

Bending bar

- length: 385mm
- cross-section: 5x20mm²
- modulus of elasticity: 210000N/mm²

Torsion bar

- length: 500mm, Ø=10mm
- shear modulus: 80000N/mm²

Weights

- small: 10x 0,5N, 1x 1N (hanger)
- large: 1x 5N, 2x 10N, 1x 20N, 1x 5N (hanger)

Strain gauge measuring point: full bridge, 350Ω

Amplifier

- measuring range: ±24mV
- resolution: 1μV
- zero balancing adjustment range: ±1mV
- supply voltage: 10VDC

Frame opening WxH: 480x450mm

230V, 50Hz, 1 phase

230V, 60Hz, 1 phase; 120V, 60Hz, 1 phase

UL/CSA optional

LxWxH: 560x410x610mm (frame)

LxWxH: 600x400x320mm (storage system)

Weight: approx. 20kg

Scope of delivery

- 1 frame
- 3 strain gauge test specimens
- 2 sets of weights
- 2 hexagon socket wrenches
- 1 measuring amplifier with strain gauge connecting cable
- 1 storage system with foam inlay
- 1 set of instructional material

FL 100

Strain gauge training system

Optional accessories

021.10001	FL 100.01	Tension bar, brass
021.10002	FL 100.02	Tension bar, copper
021.10003	FL 100.03	Tension bar, aluminium